



NAUE GmbH

Sondermaschinen - und Filterbau

Am Rotböhl 5
64331 Weiterstadt

Tel. 0 61 50 / 97 38 - 0
Fax. 0 61 50 / 70 18

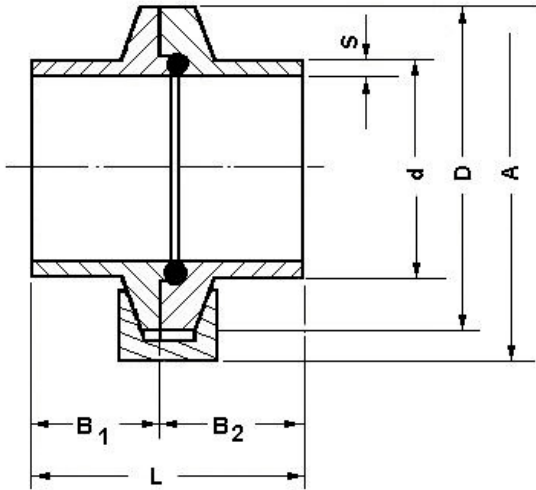

Mini-Aseptic-flange-union

Material	Clamp	1.4571 / 316 L
	Clamp with slot	1.4571 / 316 L
	Clamping ring	A2

Above steel qualities are available ex stock. Other steel qualities such as 316L and other dimensions are available upon request.

STANDARD-Design for manual welding

DN	D x s	D	A	B ₁	B ₂	L	bar	O-ring	Part n°	ISO
6		25	32	12	15	27	30		05-27002	
8	10,2 x 1,6	25	32	12	15	27	30	7,5 x 2,5	05-27003	
10	13,5 x 1,6	25	32	12	15	27	30	10,5 x 2,5	05-27004	
12	17,2 x 1,6	25	32	12	15	27	30	15,0 x 3,0	05-27005	

4	6,0 x 1,0	25	32	12	15	27	30	4,0 x 2,0	05-28001	DIN
6	8,0 x 1,0	25	32	12	15	27	30	6,0 x 2,5	05-28002	
8	10,0 x 1,0	25	32	12	15	27	30	8,0 x 2,5	05-28003	
10	12,0 x 1,0	25	32	12	15	27	30	10,5 x 2,5	05-28004	
15	18,0 x 1,5	25	32	12	15	27	30	15,0 x 3,0	05-28005	

10	13,0 x 1,5	25	32	12	15	27	30	10,5 x 2,5	05-30004	DIN line 2
15	19,0 x 1,5	25	32	12	15	27	30	15,0 x 3,0	05-30005	

¼	6,35 x 1,22	25	32	12	15	27	30	4,0 x 2,0	05-29001	US o.D. Tubing
⅜	9,53 x 1,25	25	32	12	15	27	30	7,5 x 2,5	05-29002	
½	12,70 x 1,65	25	32	12	15	27	30	10,0 x 2,5	05-29003	
¾	19,50 x 1,65	25	32	12	15	27	30	16,0 x 3,0	05-29004	

ORBITAL-Long design for automatic welding

DN	D x s	D	A	B ₁	B ₂	L	bar	O-ring	Part n°	ISO
6		25	32			55	30		05-27025	
8	10,2 x 1,6	25	32			55	30	7,5 x 2,5	05-27026	
10	13,5 x 1,6	25	32			55	30	10,5 x 2,5	05-27027	
12	17,2 x 1,6	25	32			55	30	15,0 x 3,0	05-27028	

4	6,0 x 1,0	25	32			55	30	4,0 x 2,0	05-28024	DIN
6	8,0 x 1,0	25	32			55	30	6,0 x 2,5	05-28025	
8	10,0 x 1,0	25	32			55	30	8,0 x 2,5	05-28026	
10	12,0 x 1,0	25	32			55	30	10,5 x 2,5	05-28027	
15	18,0 x 1,5	25	32			55	30	15,0 x 3,0	05-28028	

10	13,0 x 1,5	25	32			55	30	10,5 x 2,5	05-30027	DIN line 2
15	19,0 x 1,5	25	32			55	30	15,0 x 3,0	05-30028	

¼	6,35 x 1,22	25	32			55	30	4,0 x 2,0	05-29024	US o.D. Tubing
⅜	9,53 x 1,25	25	32			55	30	7,5 x 2,5	05-29025	
½	12,70 x 1,65	25	32			55	30	10,0 x 2,5	05-29026	
¾	19,50 x 1,65	25	32			55	30	16,0 x 3,0	05-29027	

Dimensions/part numbers are subject to change without notice